

Job No. : A25
 Client : AECOM
 Suburb : Yarralumla
 Location : 2. Hopetoun Crt / Adelaide Ave EB Ramps

Day/Date : Wed, 4th Nov 2015
 Weather : Fine
 Description : Classified Intersection Count
 : Intersection Diagram

Hour Starting: AM Totals
 Vehicle Type: All Vehicles

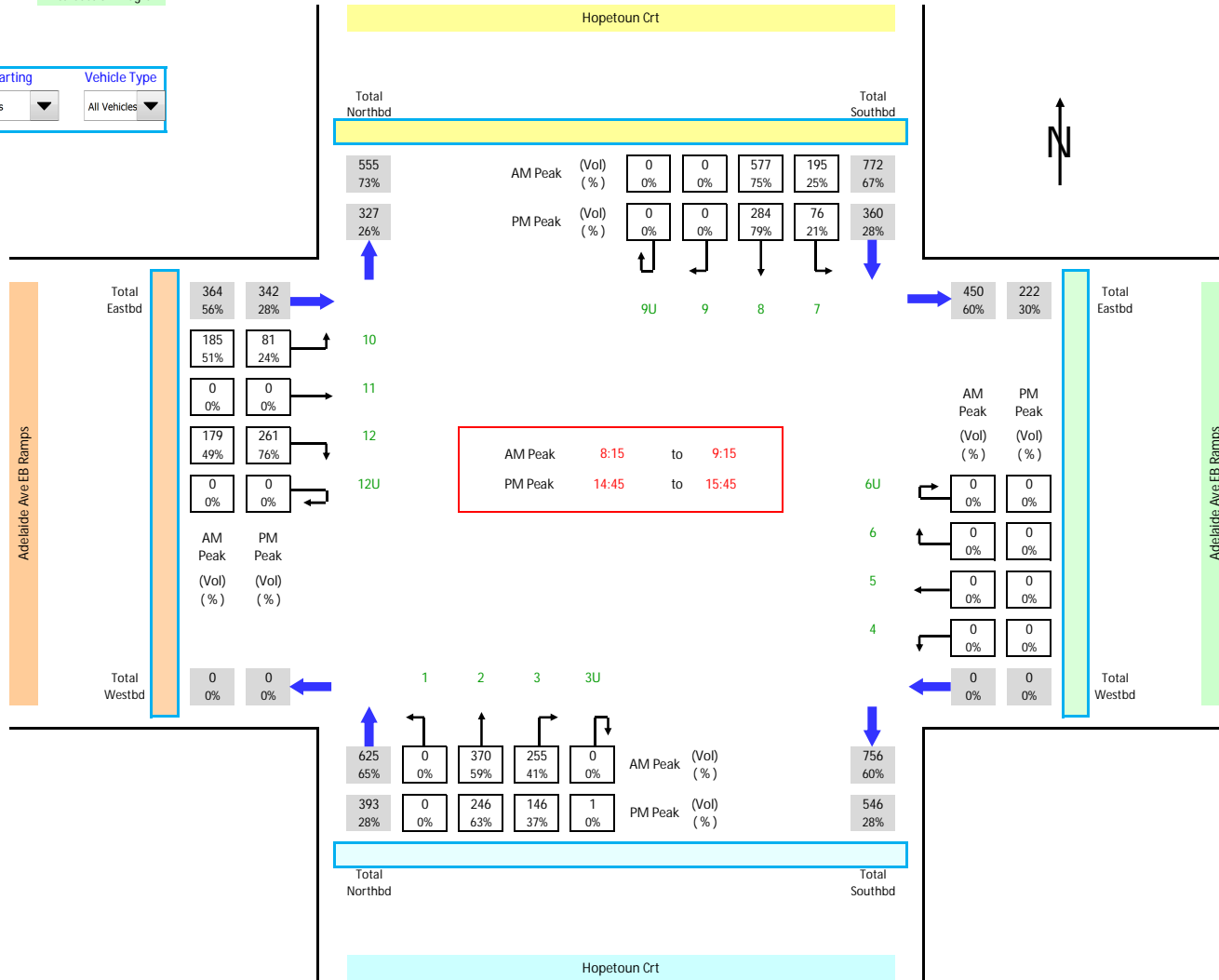

Job No. : A25
 Client : AECOM
 Suburb : Yarralumla
 Location : 3A. Dudley St / Cotter Rd (WB)

Day/Date : Sat, 7th Nov 2015
 Weather : Fine
 Description : Classified Intersection Count
 : Intersection Diagram

Hour Starting: Total
 Vehicle Type: All Vehicles

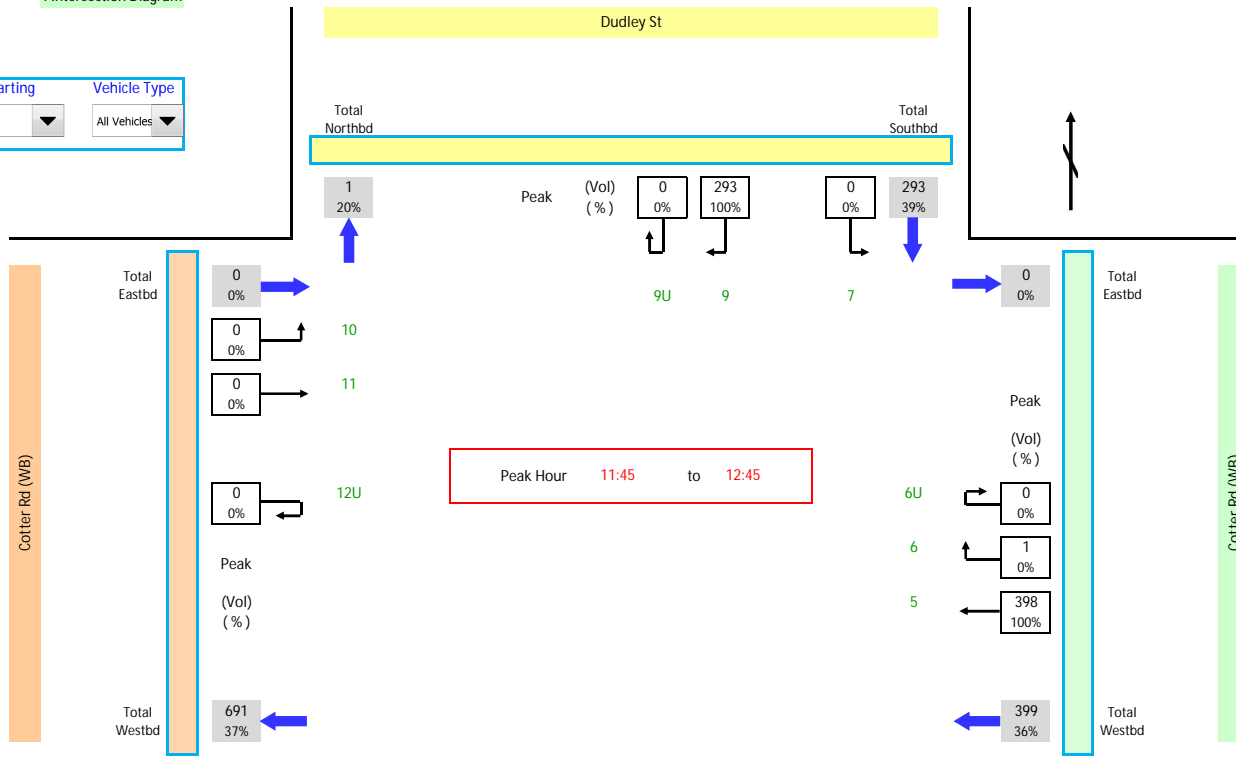

Job No. : A25
 Client : AECOM
 Suburb : Yarralumla
 Location : 3A. Dudley St / Cotter Rd (WB)

Day/Date : Wed, 4th Nov 2015
 Weather : Fine
 Description : Classified Intersection Count
 : Intersection Diagram

Hour Starting: AM Totals
 Vehicle Type: All Vehicles

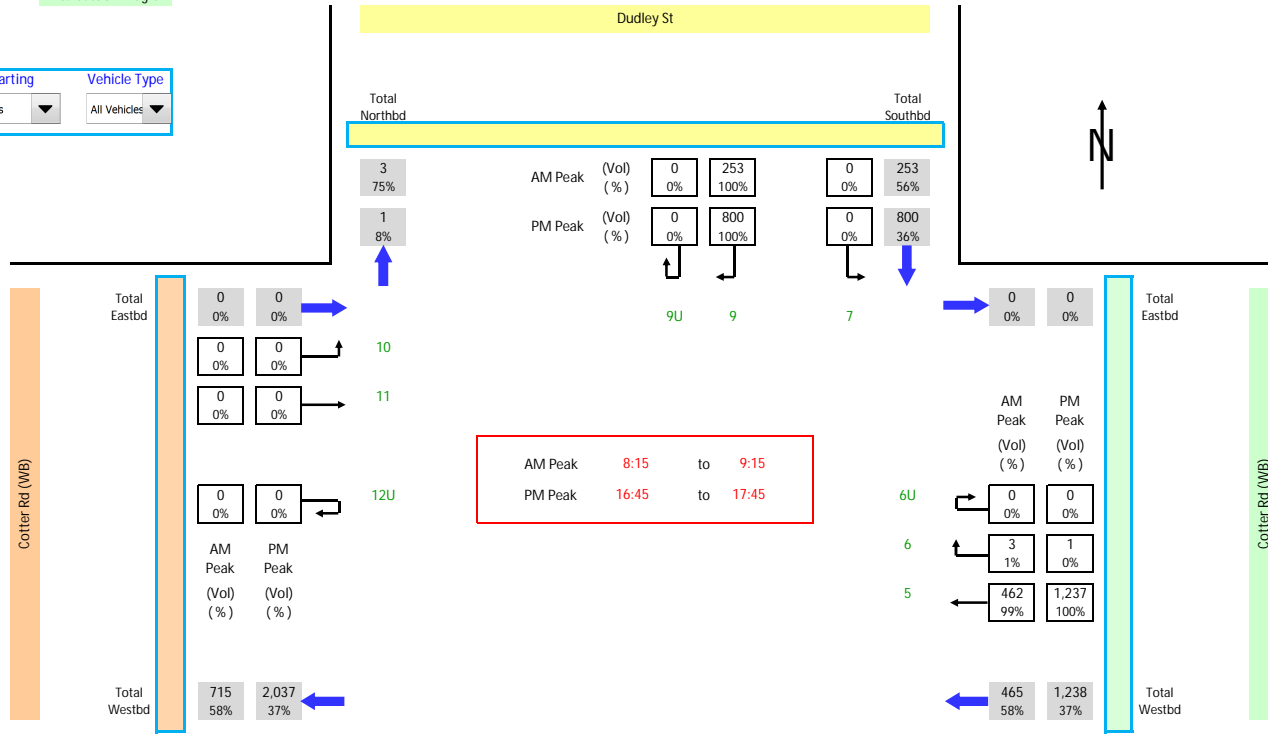

Job No. : A25
 Client : AECOM
 Suburb : Yarralumla
 Location : 3B. Dudley St / Cotter Rd (EB)

Day/Date : Sat, 7th Nov 2015
 Weather : Fine
 Description : Classified Intersection Count
 : Intersection Diagram

Hour Starting: Total
 Vehicle Type: All Vehicles

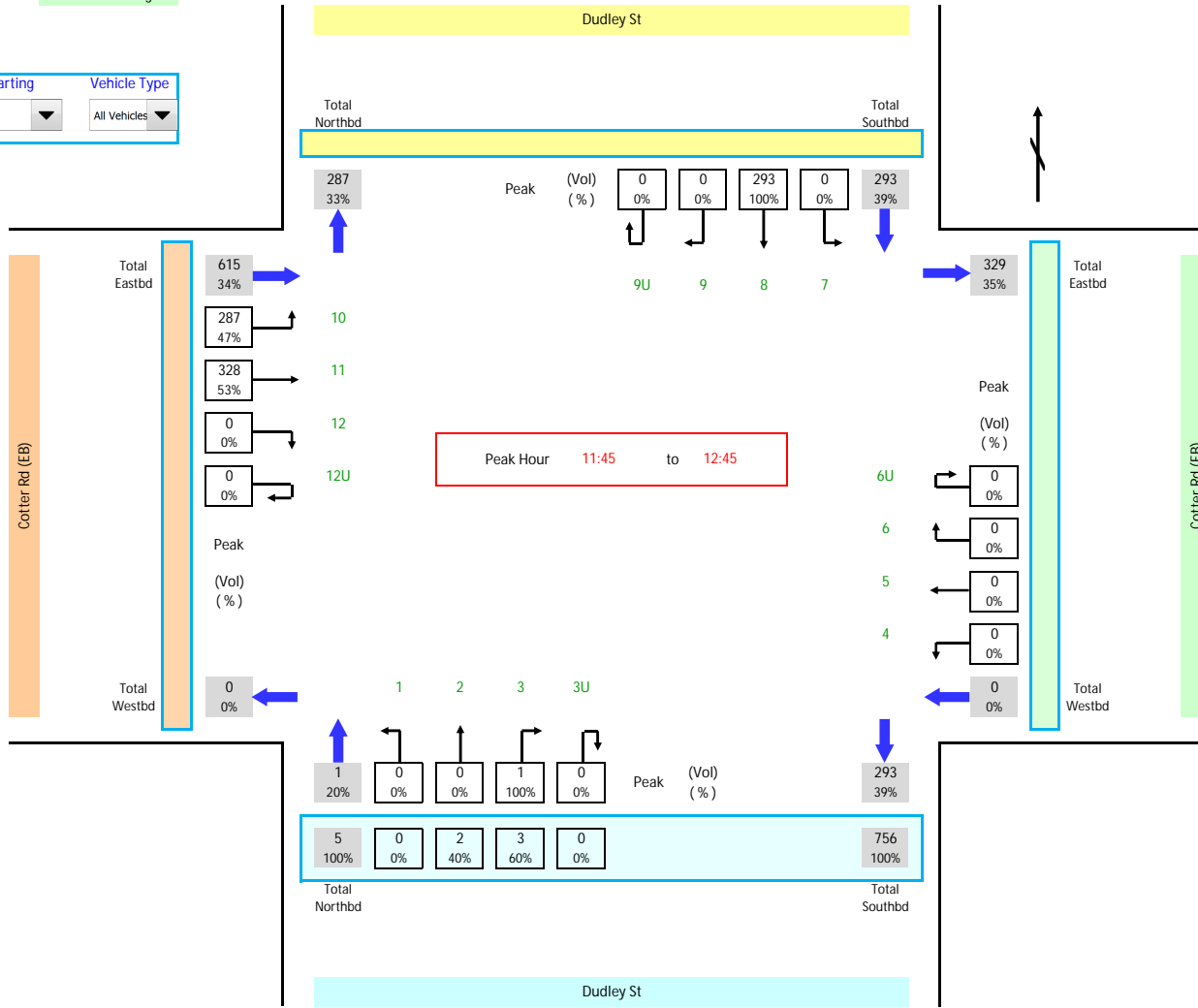

Job No. : A25
 Client : AECOM
 Suburb : Yarralumla
 Location : 3B. Dudley St / Cotter Rd (EB)

Day/Date : Wed, 4th Nov 2015
 Weather : Fine
 Description : Classified Intersection Count
 : Intersection Diagram

Hour Starting: AM Totals
 Vehicle Type: All Vehicles

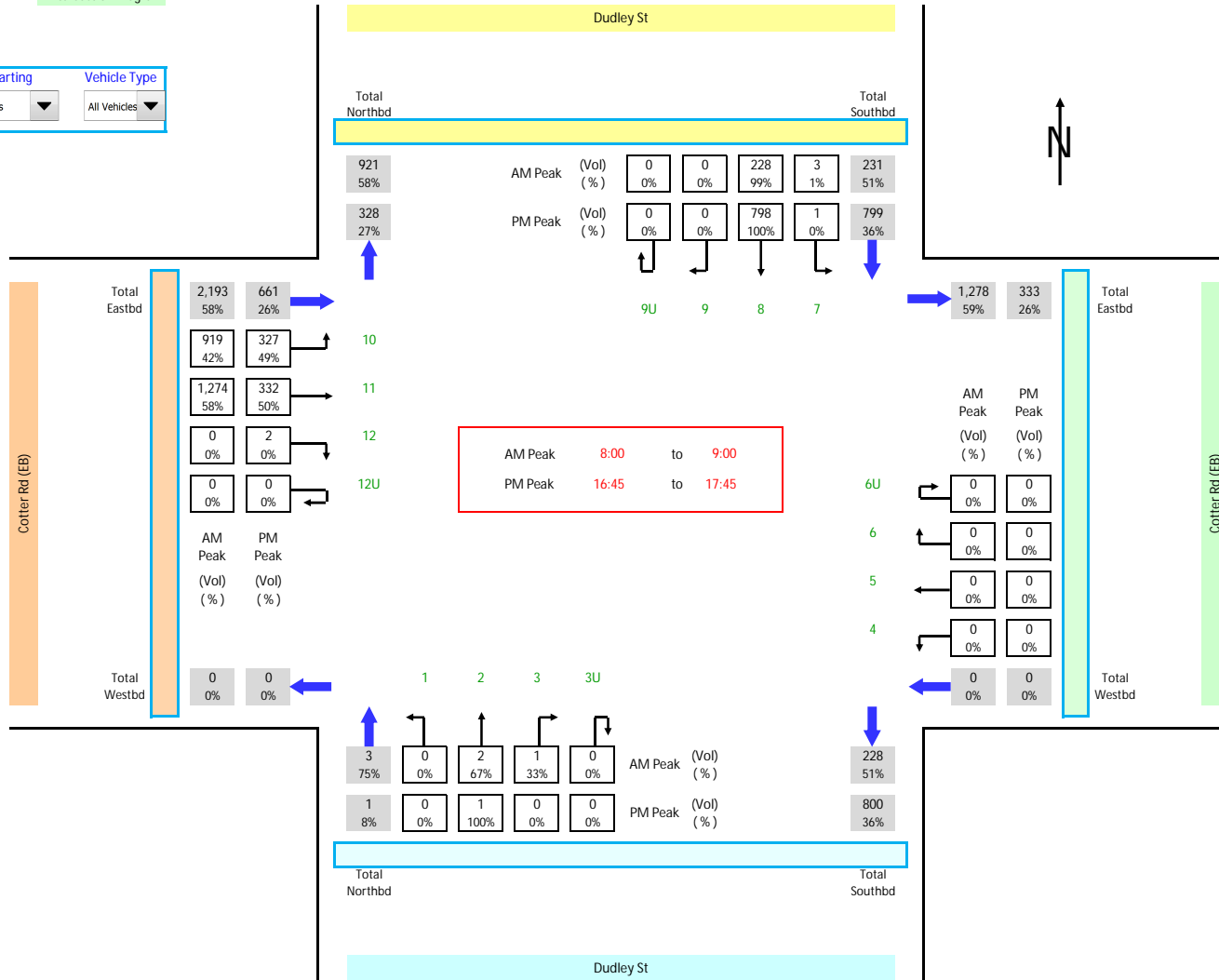

Job No. : A25
 Client : AECOM
 Suburb : Yarralumla
 Location : 4. Kent St / Adelaide Ave Off-Ramp

Day/Date : Sat, 7th Nov 2015
 Weather : Fine
 Description : Classified Intersection Count
 : Intersection Diagram

Hour Starting: Total
 Vehicle Type: All Vehicles

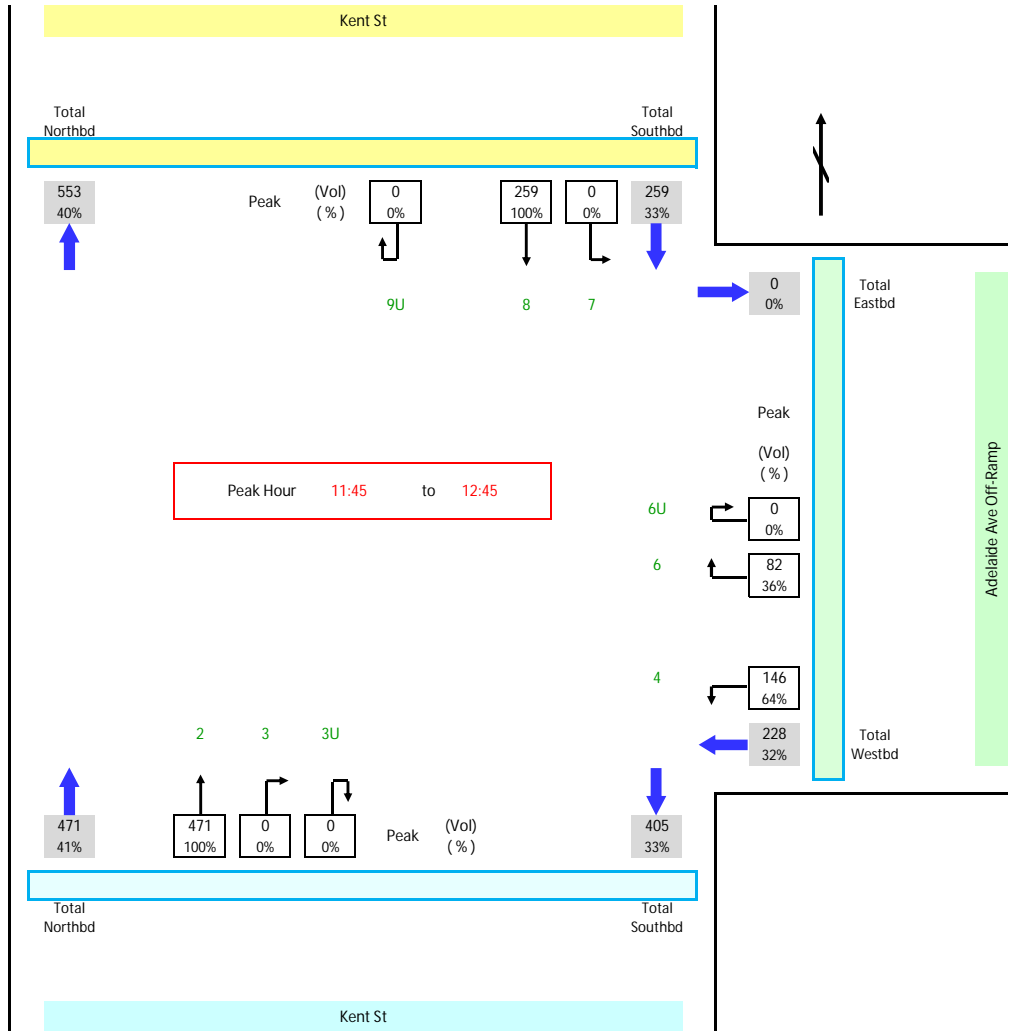

Job No. : A25
 Client : AECOM
 Suburb : Yarralumla
 Location : 4. Kent St / Adelaide Ave Off-Ramp

Day/Date : Wed, 4th Nov 2015
 Weather : Fine
 Description : Classified Intersection Count
 : Intersection Diagram

Hour Starting Vehicle Type

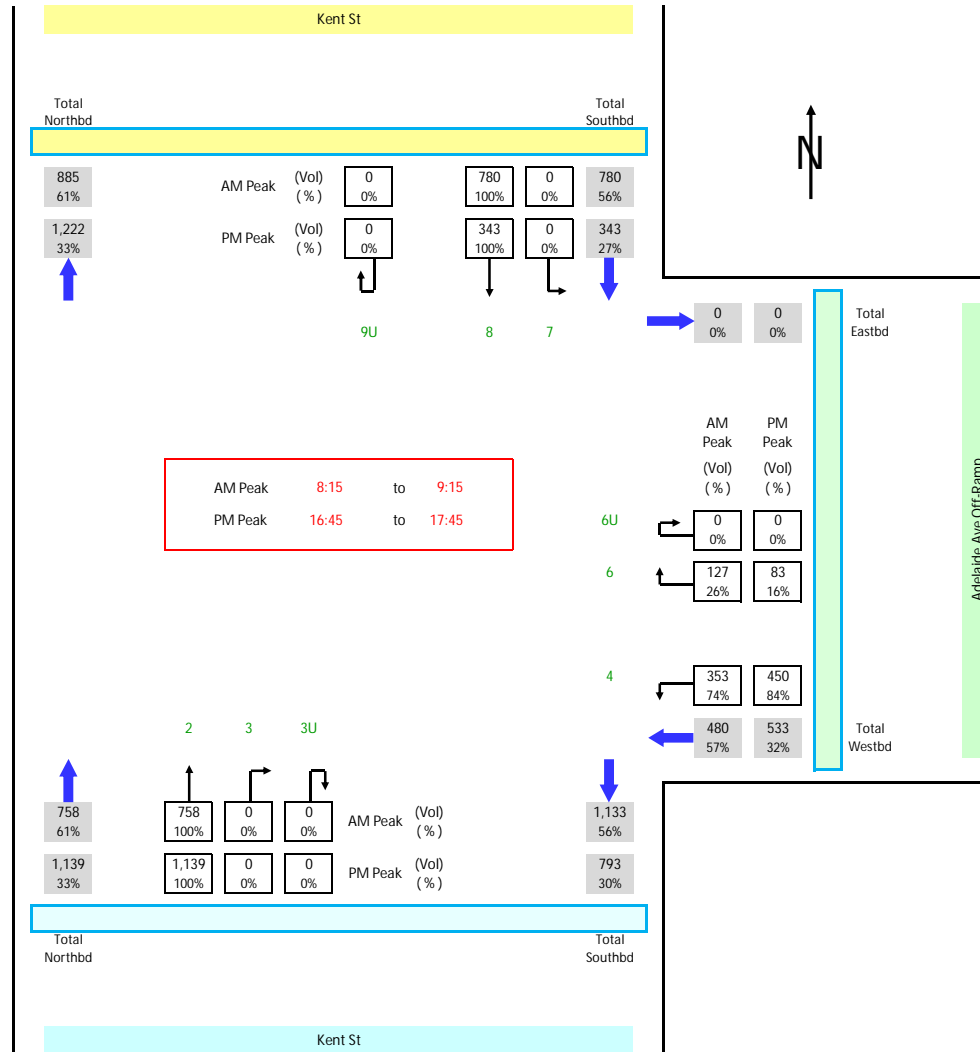

Job No. : A25
 Client : AECOM
 Suburb : Yarralumla
 Location : 5. Kent St / Denison St

Day/Date : Sat, 7th Nov 2015
 Weather : Fine
 Description : Classified Intersection Count
 : Intersection Diagram

Hour Starting: Total
 Vehicle Type: All Vehicles

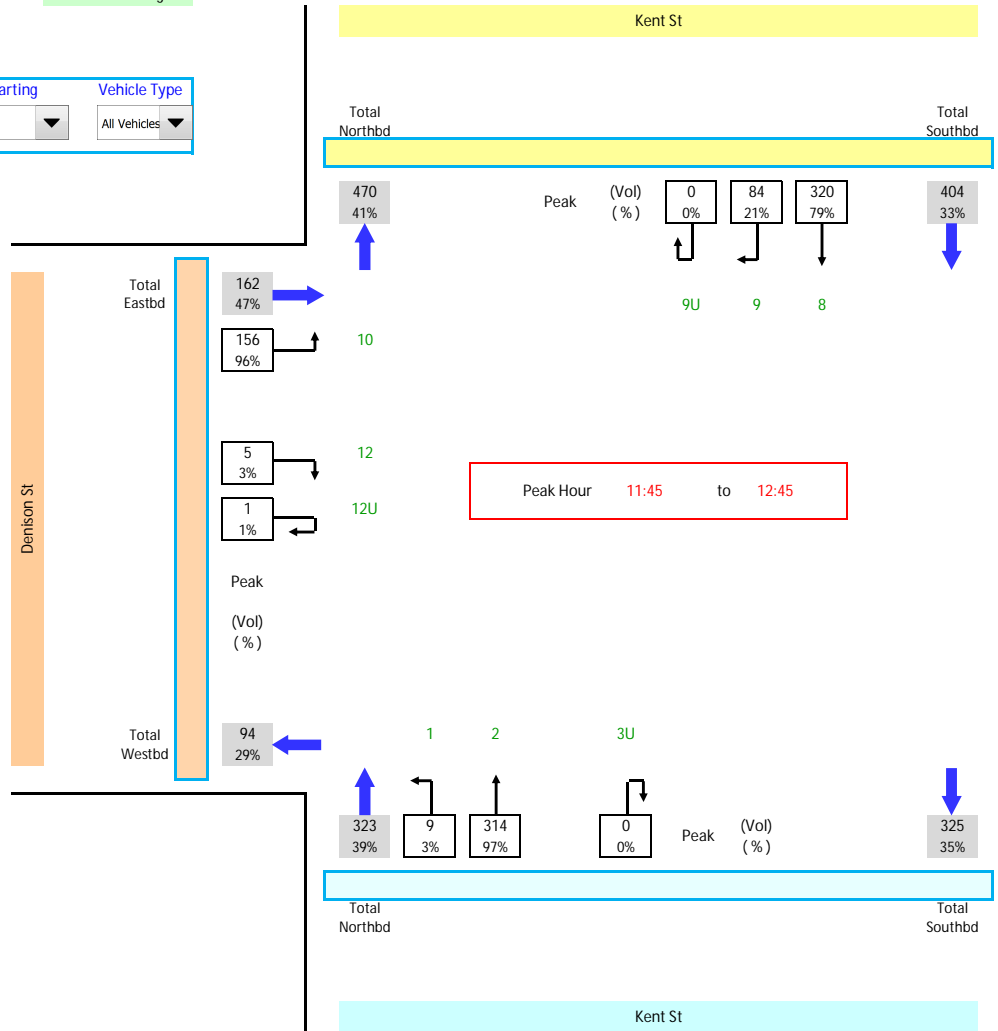

Job No. : A25
 Client : AECOM
 Suburb : Yarralumla
 Location : 5. Kent St / Denison St

Day/Date : Wed, 4th Nov 2015
 Weather : Fine
 Description : Classified Intersection Count
 : Intersection Diagram

Hour Starting: AM Totals
 Vehicle Type: All Vehicles

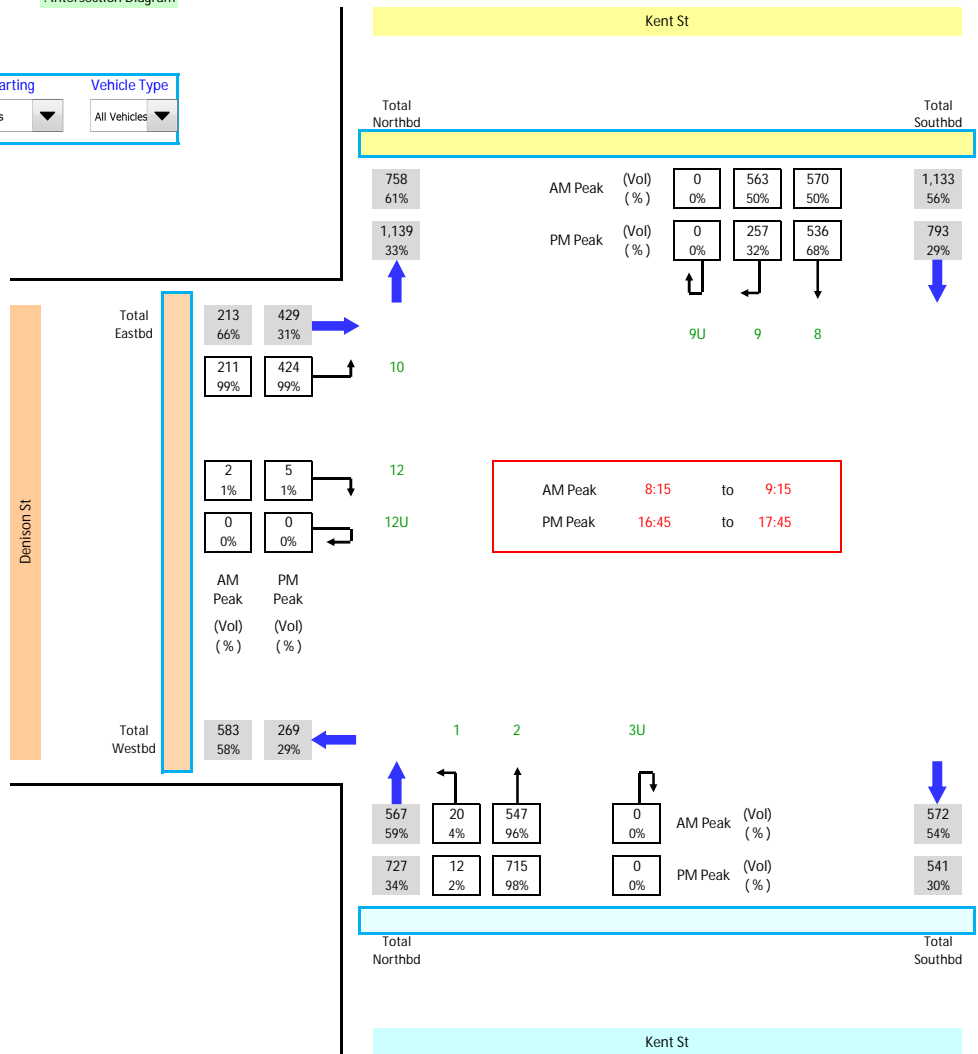

Job No. : A25
 Client : AECOM
 Suburb : Yarralumla
 Location : 6. Novar St / Dudley St / Adelaide Ave On-Ramp

Day/Date : Sat, 7th Nov 2015
 Weather : Fine
 Description : Classified Intersection Count
 : Intersection Diagram

Hour Starting: Vehicle Type:

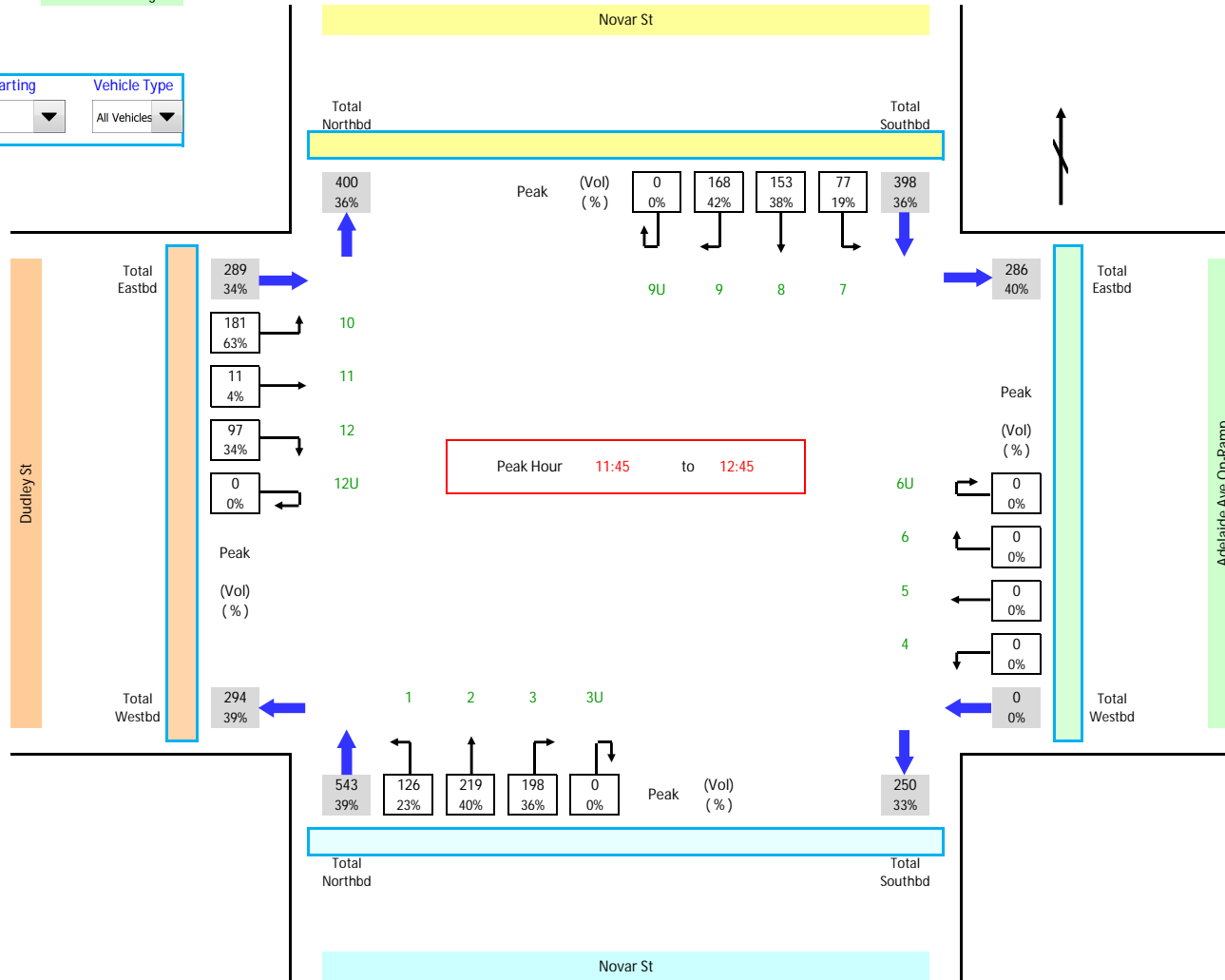

Job No. : A25
 Client : AECOM
 Suburb : Yarralumla
 Location : 6. Novar St / Dudley St / Adelaide Ave On-Ramp

Day/Date : Wed, 4th Nov 2015
 Weather : Fine
 Description : Classified Intersection Count
 : Intersection Diagram

Hour Starting: AM Totals
 Vehicle Type: All Vehicles

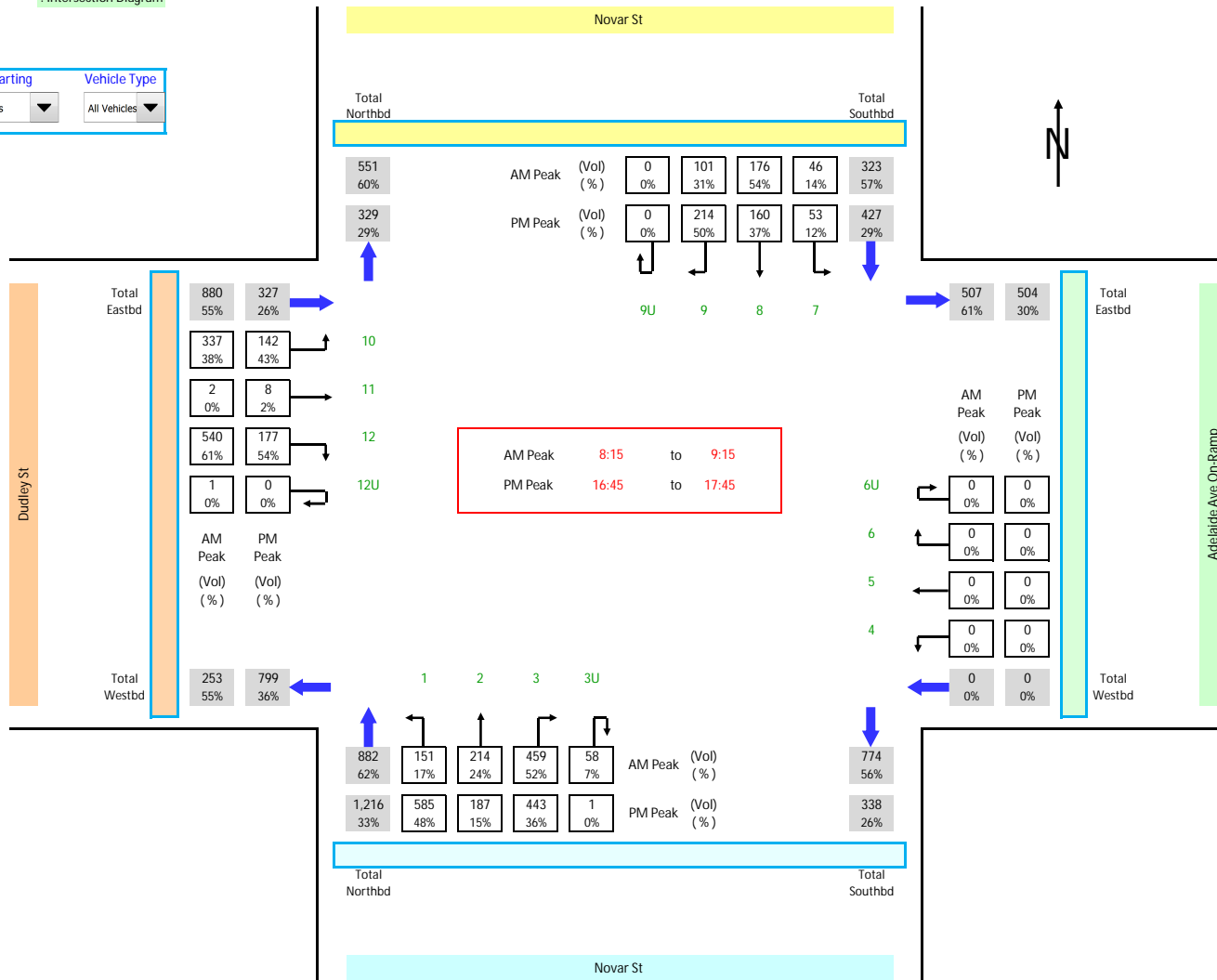

Job No. : A25
 Client : AECOM
 Suburb : Yarralumla
 Location : 7. Novar St / Kintone Cres

Day/Date : Sat, 7th Nov 2015
 Weather : Fine
 Description : Classified Intersection Count
 : Intersection Diagram

Hour Starting: Vehicle Type:

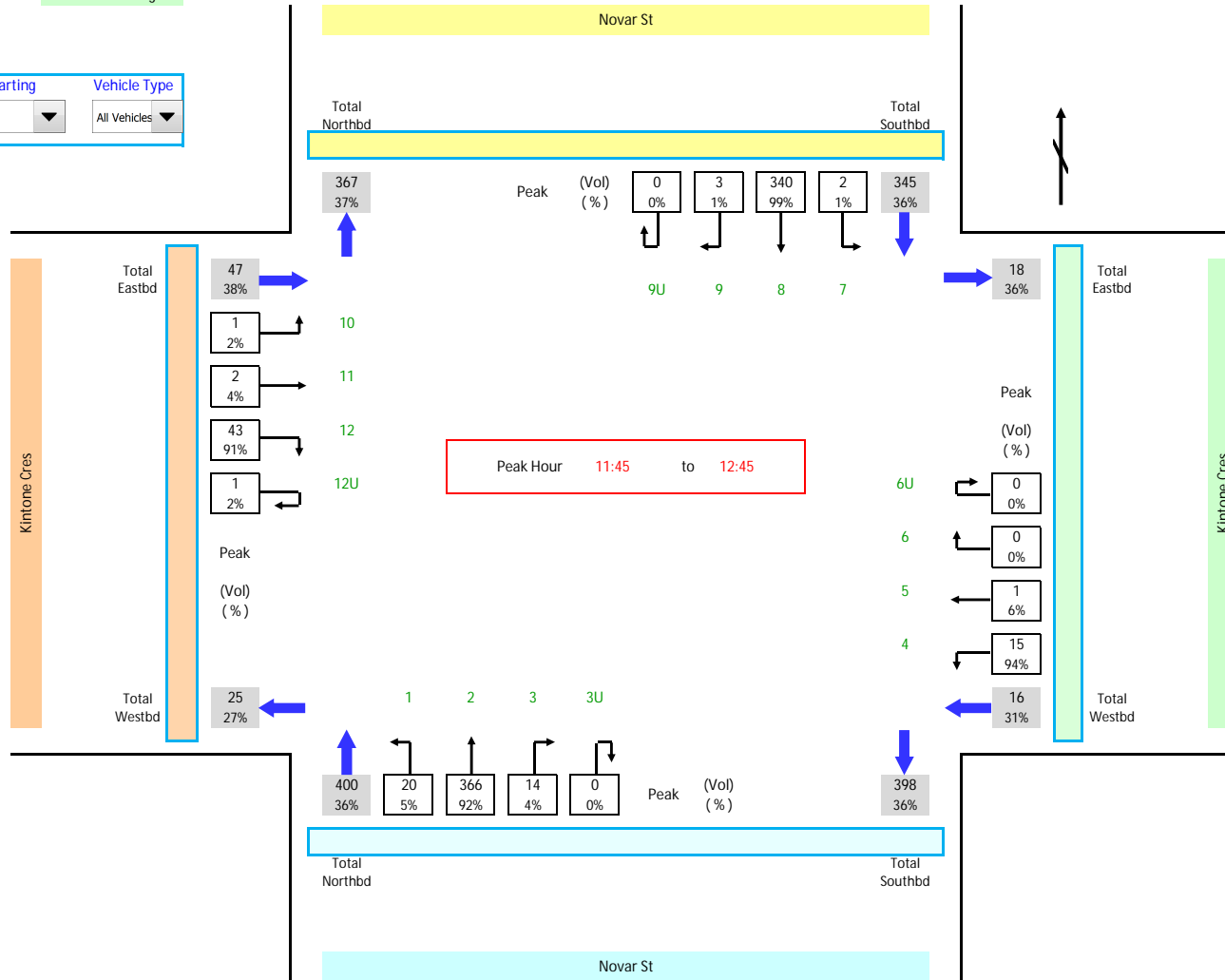

Job No. : A25
 Client : AECOM
 Suburb : Yarralumla
 Location : 7. Novar St / Kintone Cres

Day/Date : Wed, 4th Nov 2015
 Weather : Fine
 Description : Classified Intersection Count
 : Intersection Diagram

Hour Starting: AM Totals
 Vehicle Type: All Vehicles

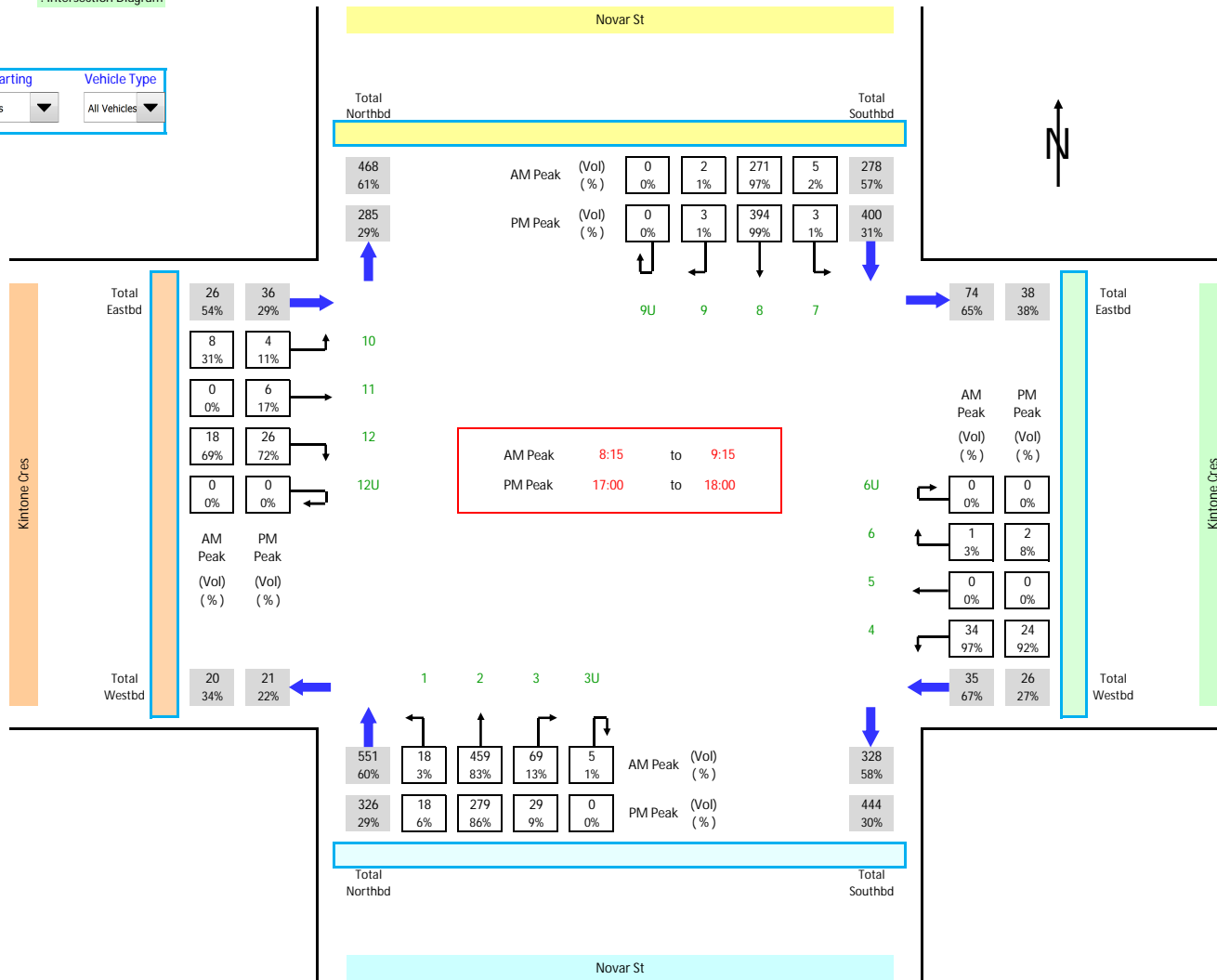

Job No. : A25
 Client : AECOM
 Suburb : Yarralumla
 Location : 1. Hopetoun Cr / Weston St / Hampton Cr

Day/Date : Sat, 7th Nov 2015
 Weather : Fine
 Description : Classified Intersection Count
 : Intersection Diagram

Hour Starting: Vehicle Type:

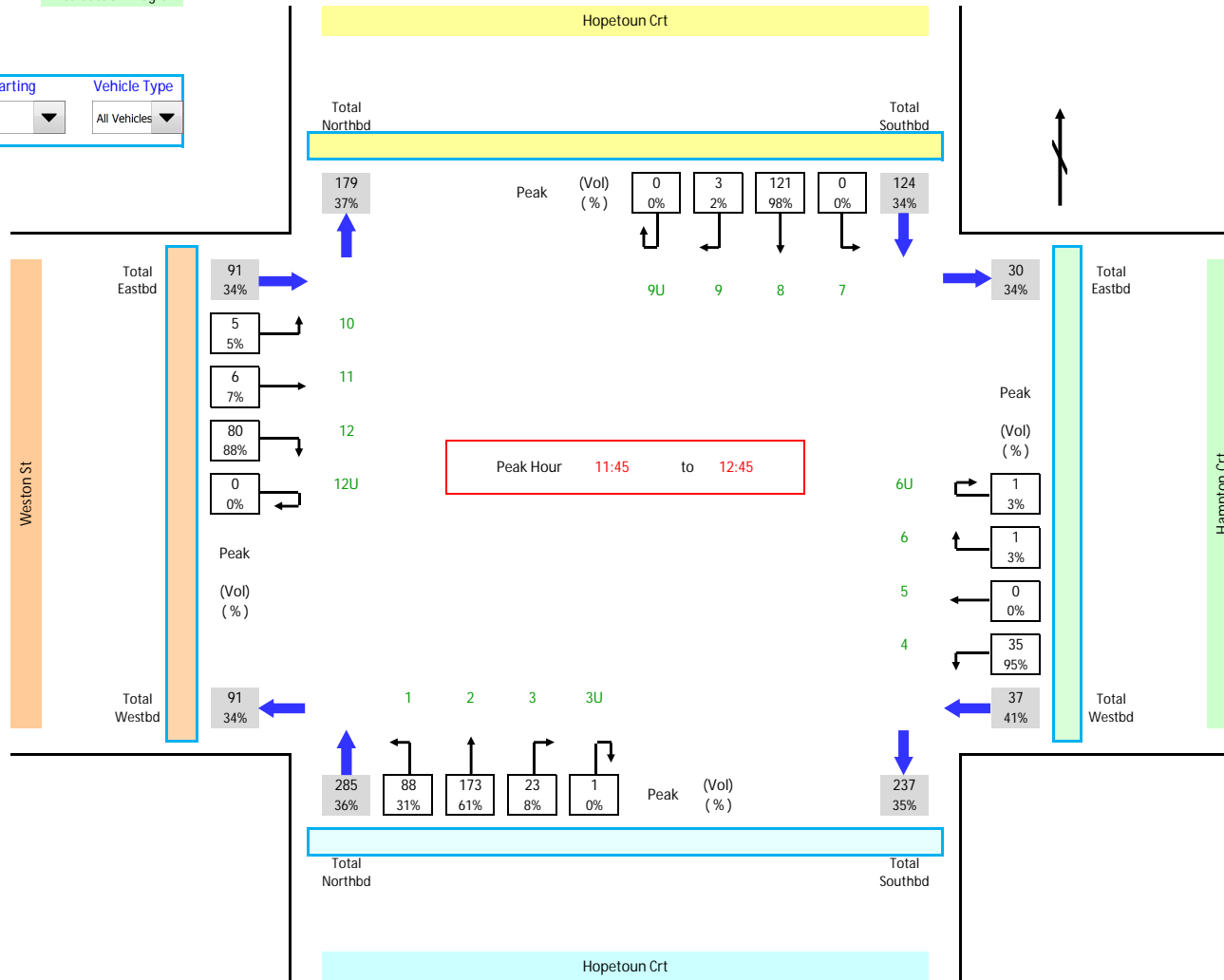

Job No. : A25
 Client : AECOM
 Suburb : Yarralumla
 Location : 1. Hopetoun Cr / Weston St / Hampton Cr

Day/Date : Wed, 4th Nov 2015
 Weather : Fine
 Description : Classified Intersection Count
 : Intersection Diagram

Hour Starting: AM Totals
 Vehicle Type: All Vehicles

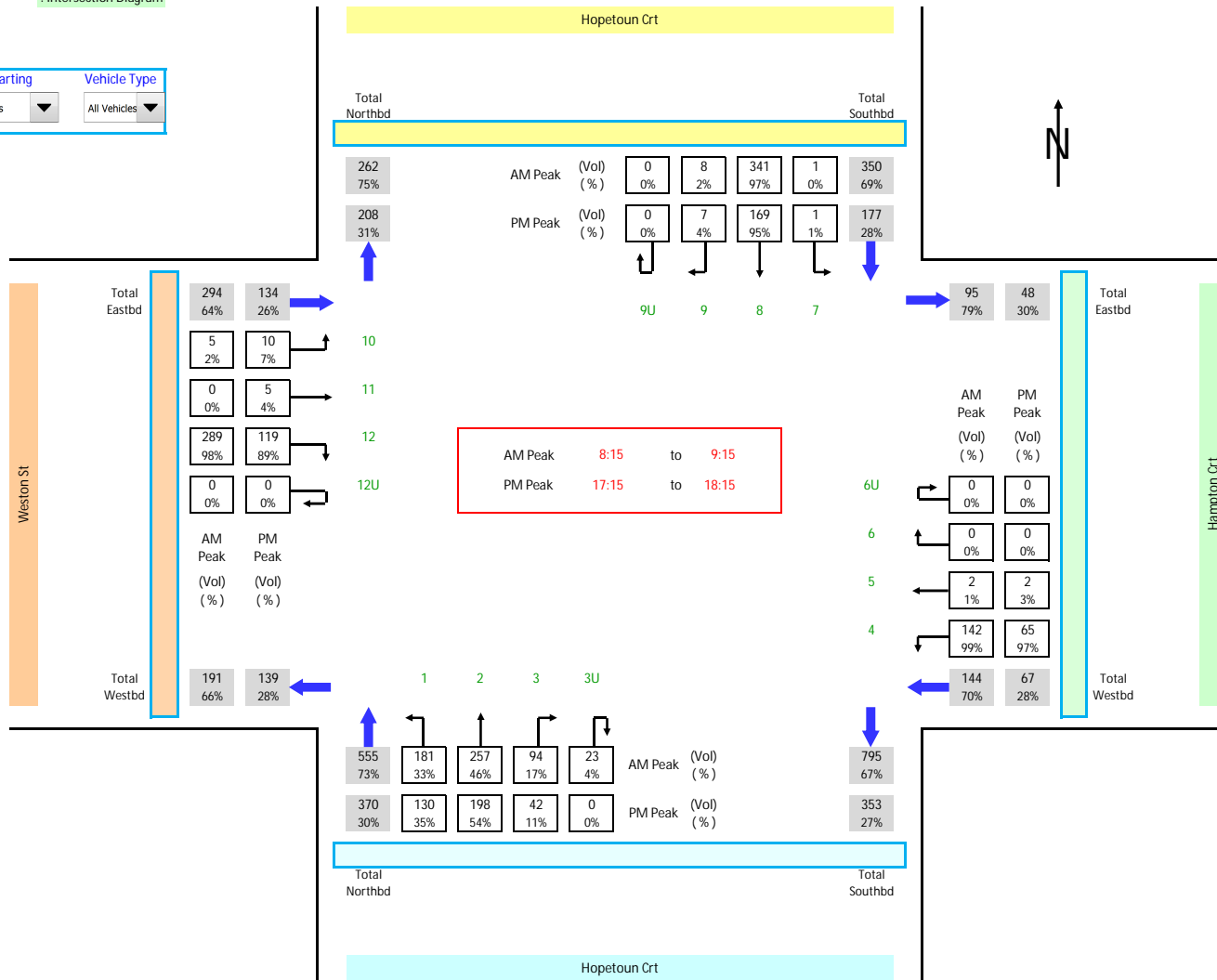

Job No. : A25
 Client : AECOM
 Suburb : Yarralumla
 Location : 2. Hopetoun Crt / Adelaide Ave EB Ramps

Day/Date : Sat, 7th Nov 2015
 Weather : Fine
 Description : Classified Intersection Count
 : Intersection Diagram

Hour Starting: Vehicle Type:

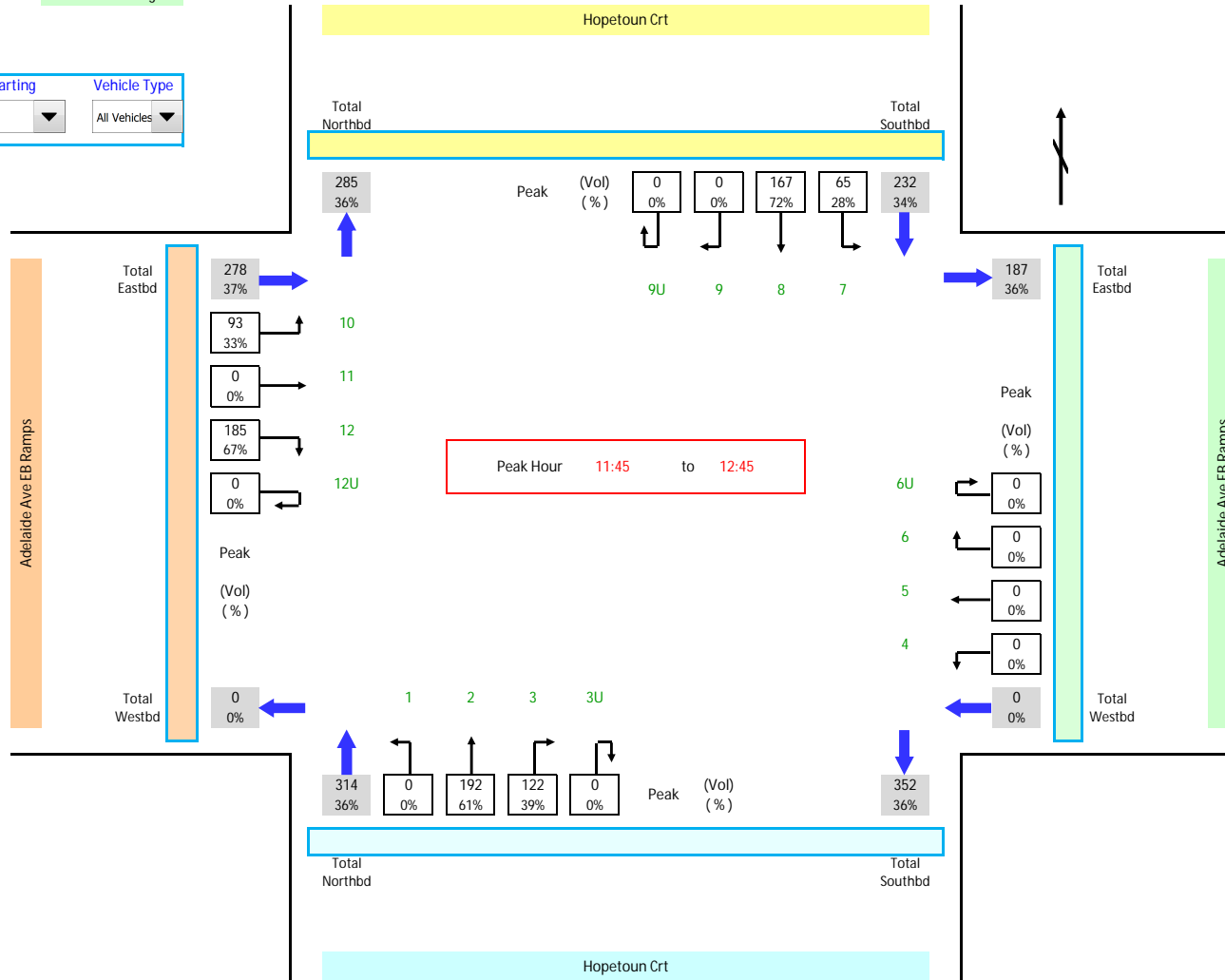

TURNING MOVEMENT SURVEY
Banks St and Bentham St, Yarralumla

Weather:	Overcast
Suburban:	Yarralumla
Customer:	AECOM

Survey Start	
AM:	7:30
PM:	16:30
Wkend:	11:30

Peakhour	
AM:	8:00 AM-9:00 AM
PM:	4:45 PM-5:45 PM
Wkend:	11:45 AM-12:45 PM

Graphic

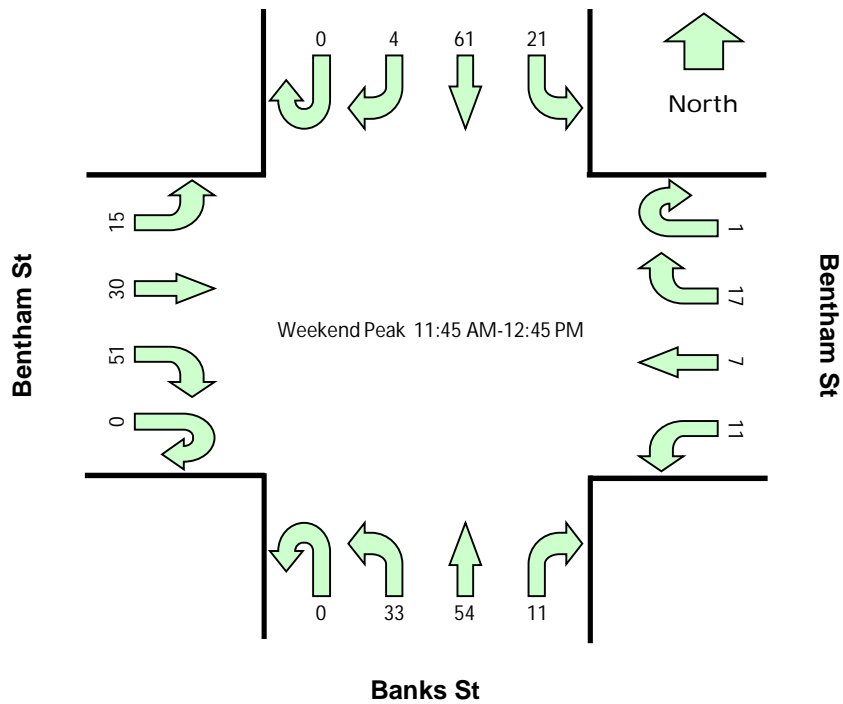
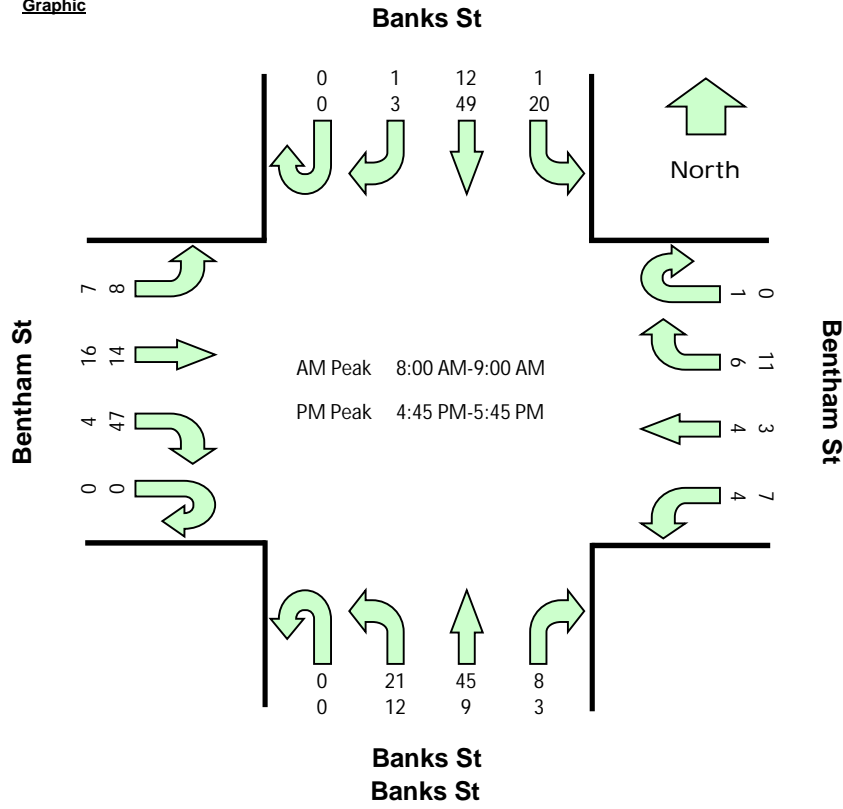

TURNING MOVEMENT SURVEY
Novar St and Bentham St, Yarralumla

Weather:	Overcast
Suburban:	Yarralumla
Customer:	AECOM

Survey Start	
AM:	7:30
PM:	16:30
Wkend:	11:30

Peakhour	
AM:	8:00 AM-9:00 AM
PM:	5:00 PM-6:00 PM
Wkend:	11:45 AM-12:45 PM

Graphic

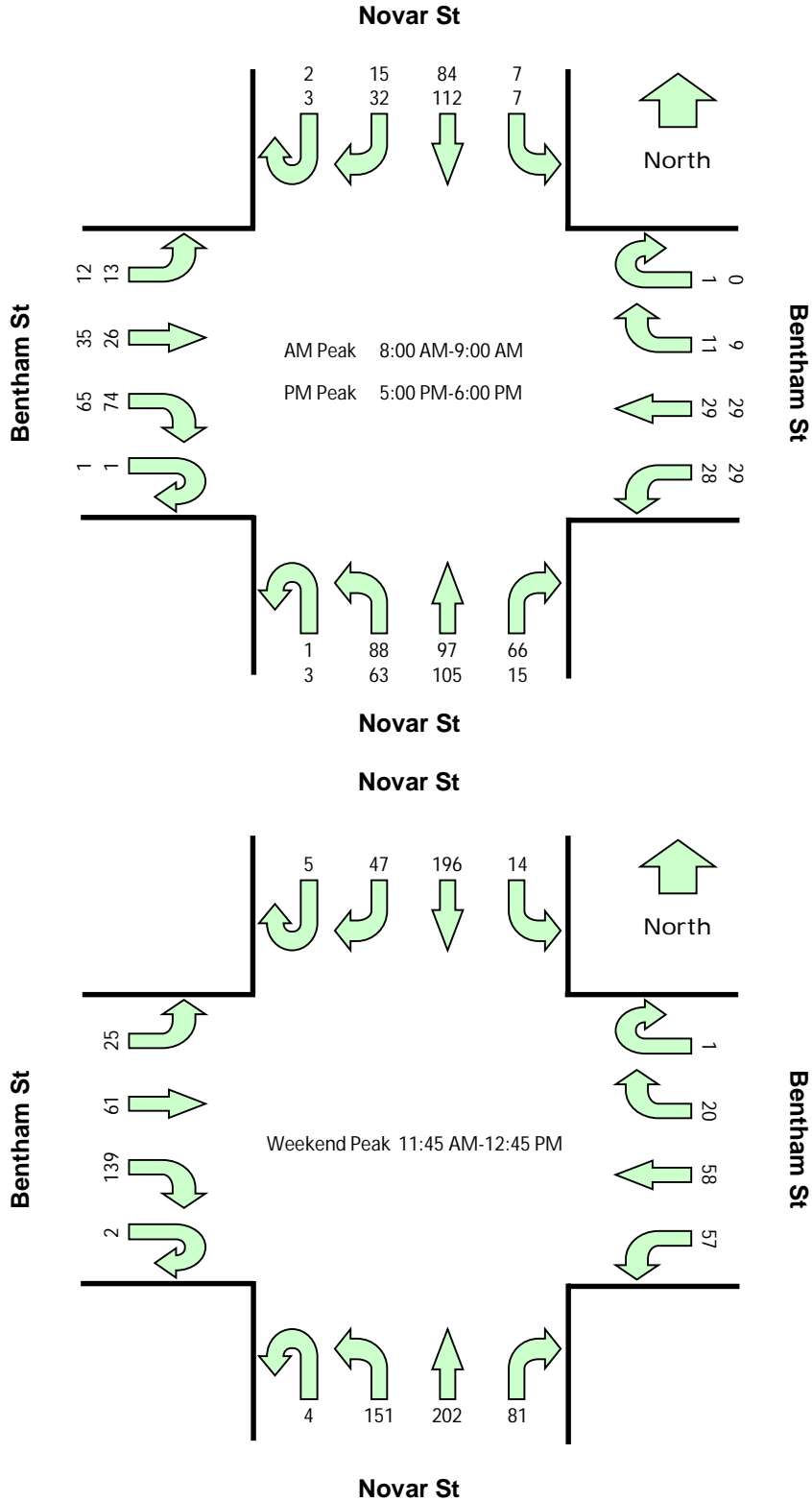

TURNING MOVEMENT SURVEY
Novar St and Weston St, Yarralumla

Weather:	Overcast
Suburban:	Yarralumla
Customer:	AECOM

Survey Start	
AM:	7:30
PM:	16:30
Wkend:	11:30

Peakhour	
AM:	8:00 AM-9:00 AM
PM:	4:30 PM-5:30 PM
Wkend:	11:45 AM-12:45 PM

Graphic

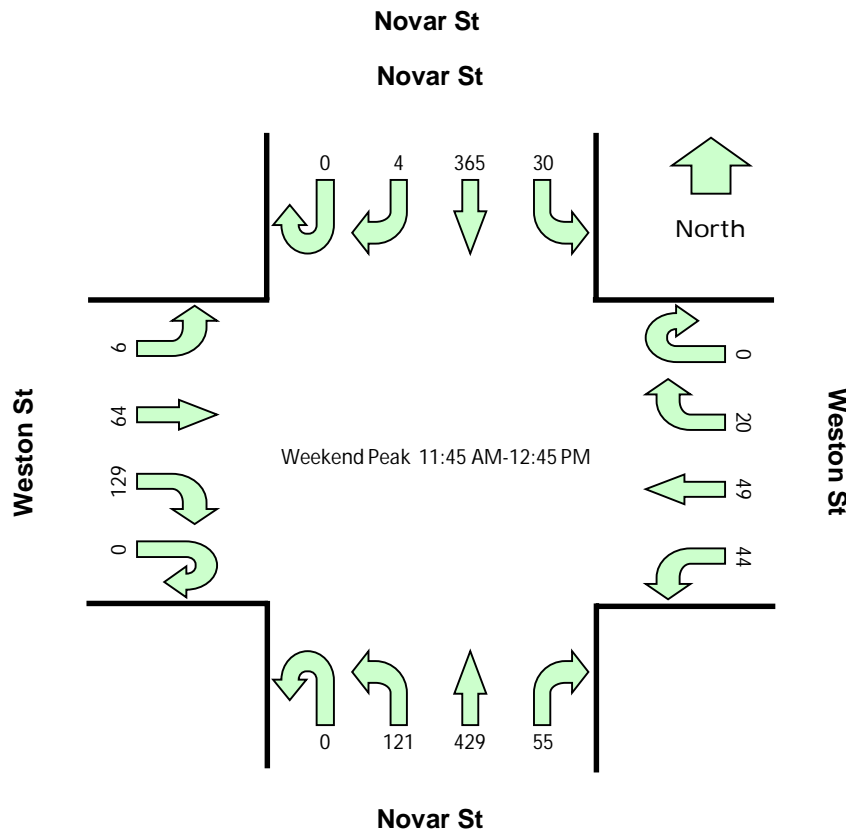
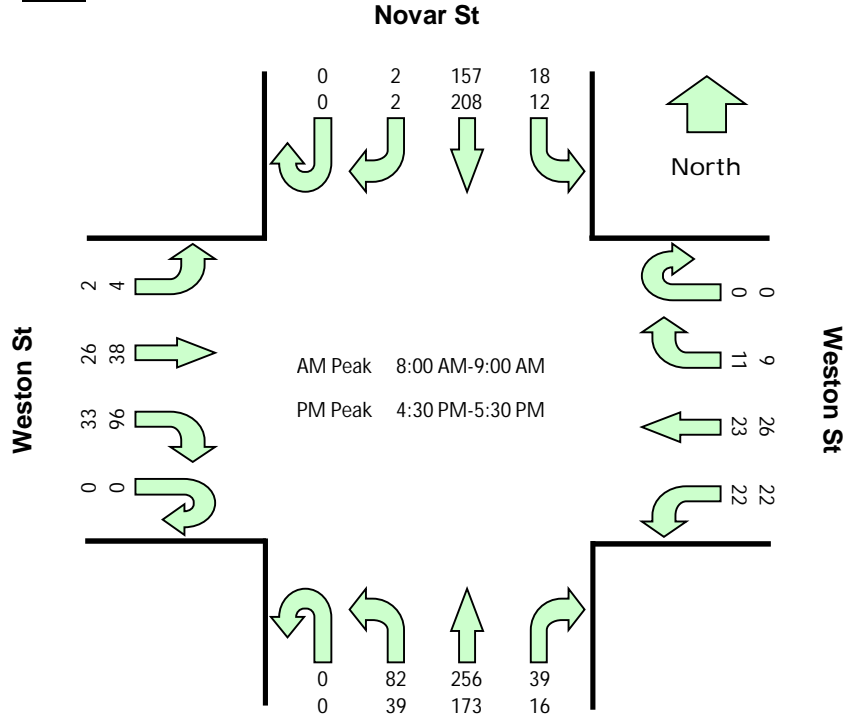

6. Loftus St - btw Loch St and Macgillivray St



Choose Direction

Combined

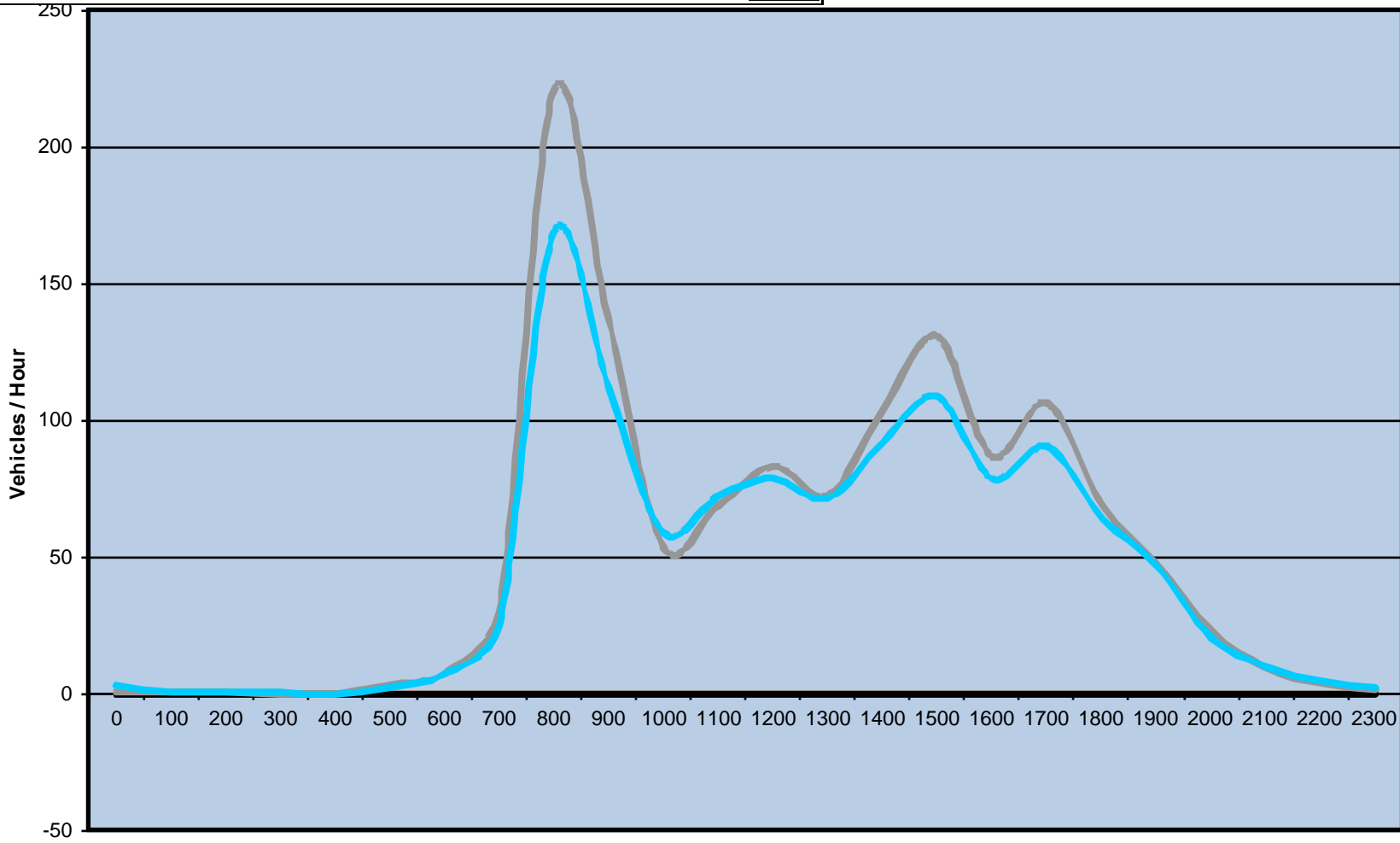

- Mon
- Tue
- Wed
- Thu
- Fri
- Sat
- Sun
- 5 Day
- 7 Day

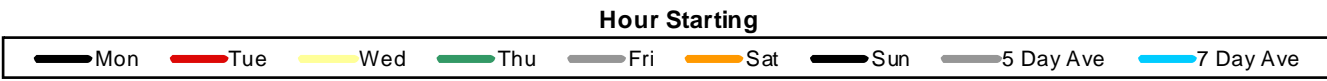

1. Novar St - btw Turner Pl and Schlich St



Choose Direction

Combined

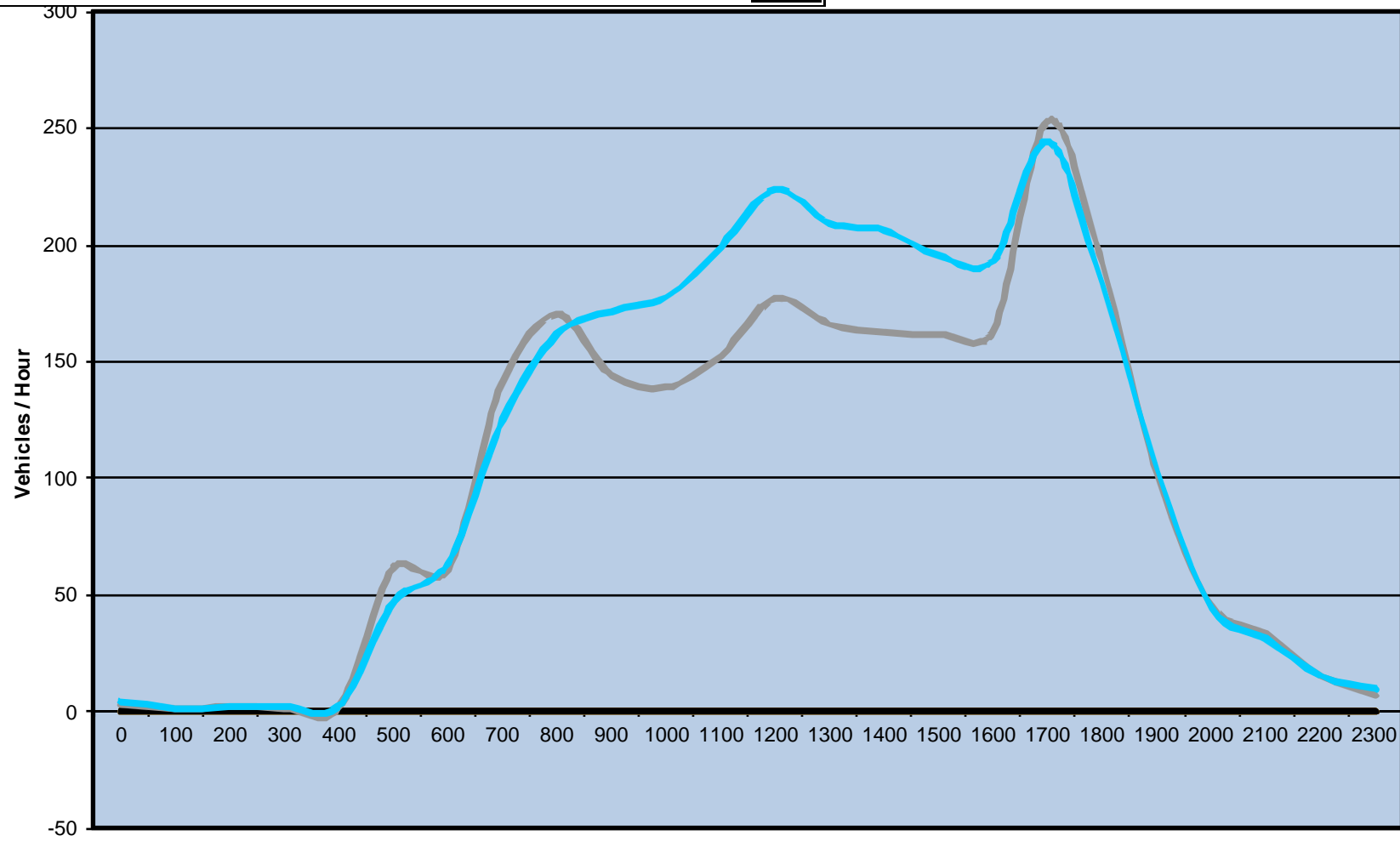

- Mon
- Tue
- Wed
- Thu
- Fri
- Sat
- Sun
- 5 Day
- 7 Day

Hour Starting

Mon Tue Wed Thu Fri Sat Sun 5 Day Ave 7 Day Ave

2. Bentham St - btw Banks St and Hutchins St



Choose Direction

Combined

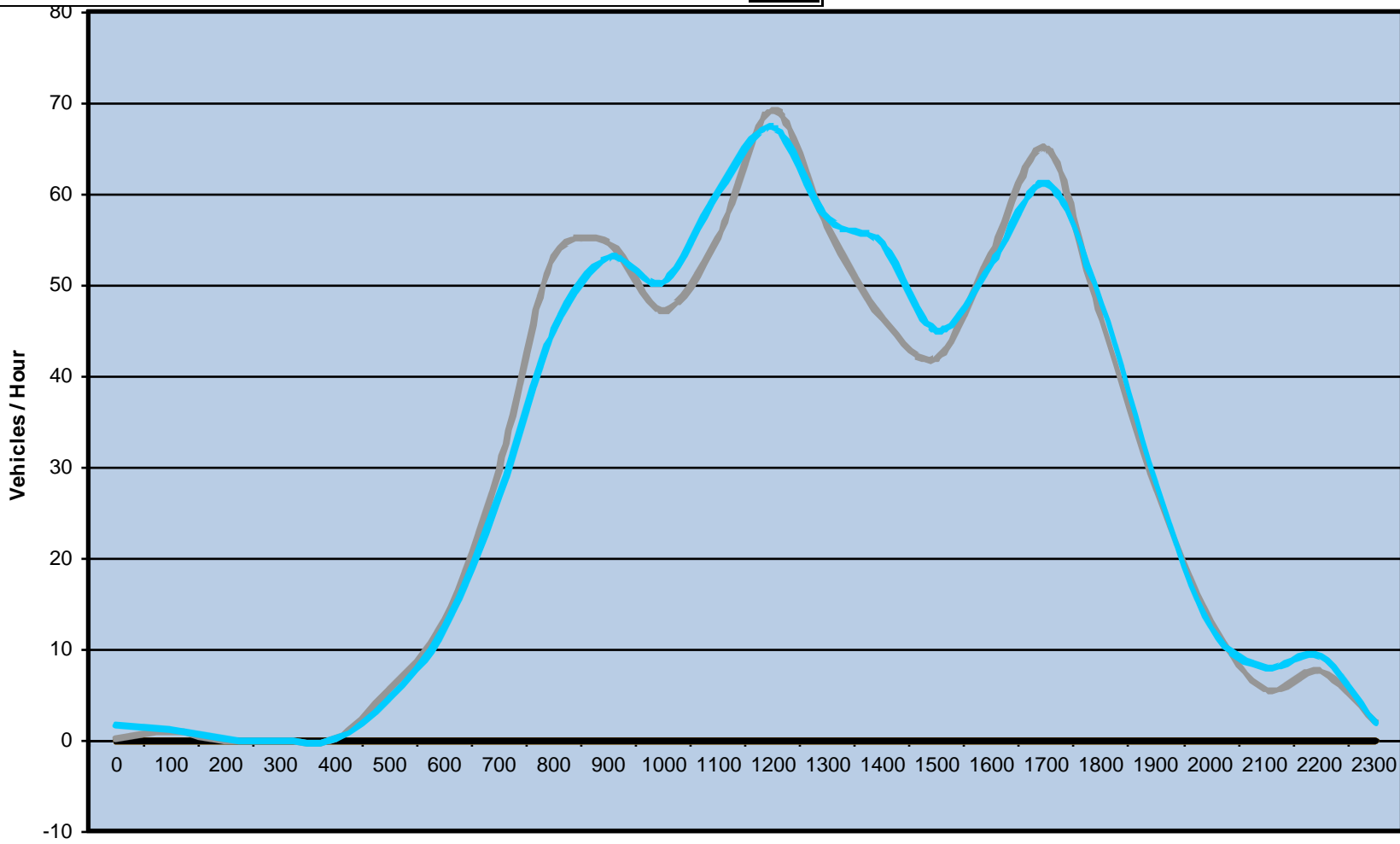

- Mon
- Tue
- Wed
- Thu
- Fri
- Sat
- Sun
- 5 Day
- 7 Day

Hour Starting

Mon	Tue	Wed	Thu	Fri	Sat	Sun	5 Day Ave	7 Day Ave
-----	-----	-----	-----	-----	-----	-----	-----------	-----------

3. Weston St - btw Hutchins St and Novar St



Choose Direction

Combined

- Mon
- Tue
- Wed
- Thu
- Fri
- Sat
- Sun
- 5 Day
- 7 Day

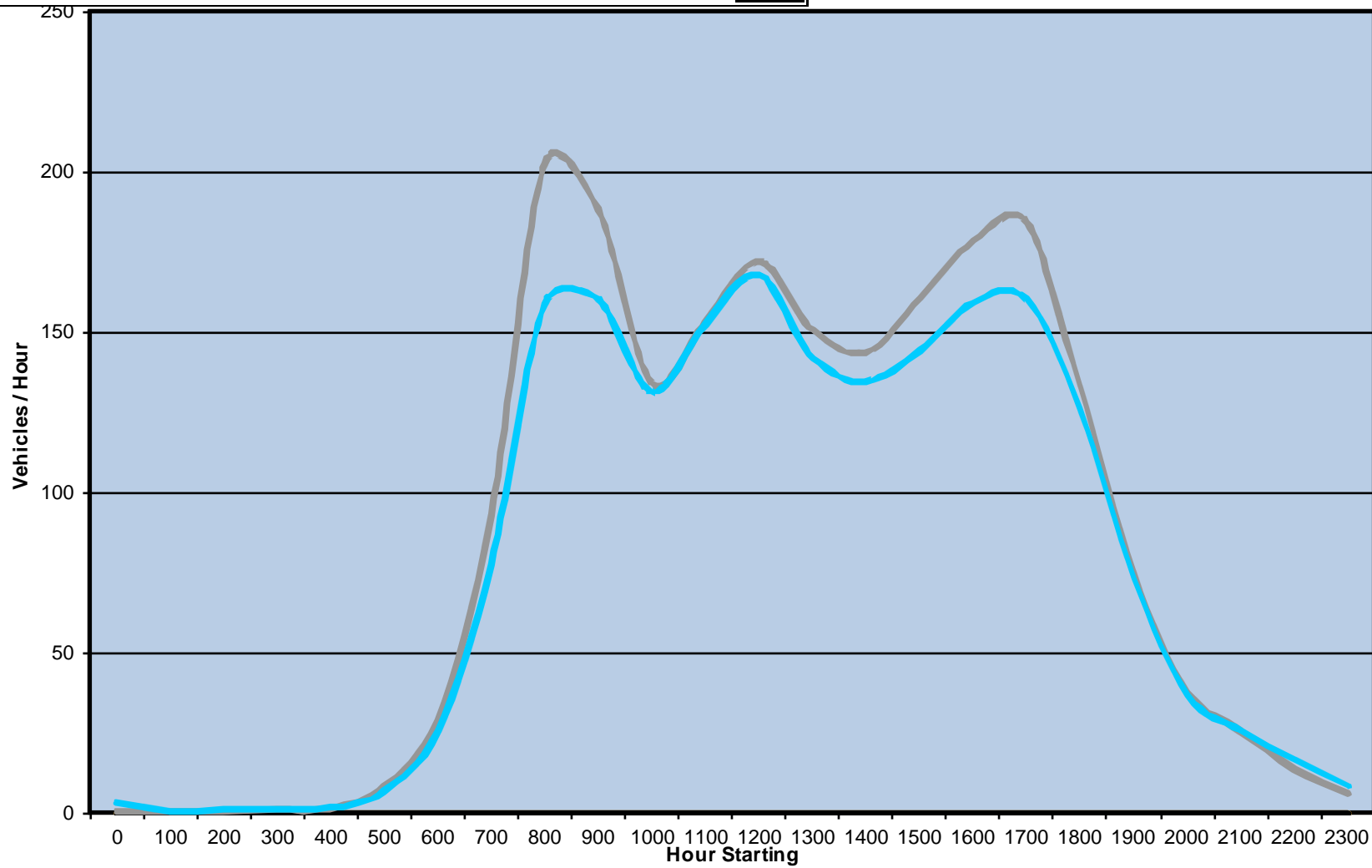

— Mon — Tue — Wed — Thu — Fri — Sat — Sun — 5 Day Ave — 7 Day Ave

5. Denman St - btw Maxwell St and Wools St



Choose Direction

Combined

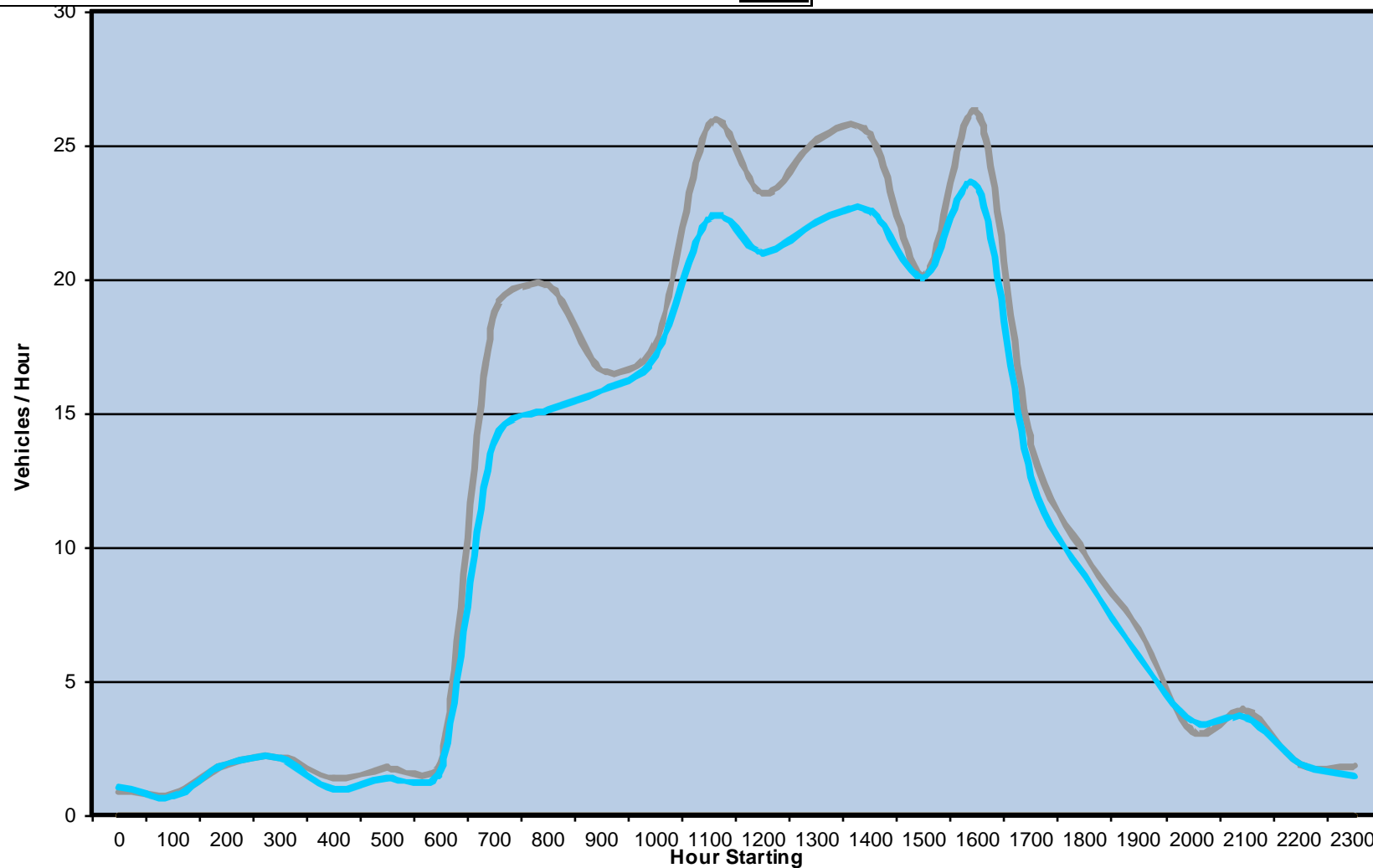

Legend: Mon (black), Tue (red), Wed (yellow), Thu (green), Fri (grey), Sat (orange), Sun (black), 5 Day Ave (grey), 7 Day Ave (cyan)

- Mon
- Tue
- Wed
- Thu
- Fri
- Sat
- Sun
- 5 Day
- 7 Day

4. Kintore Cres - btw Fraser Pl and Novar St



Choose Direction

Combined

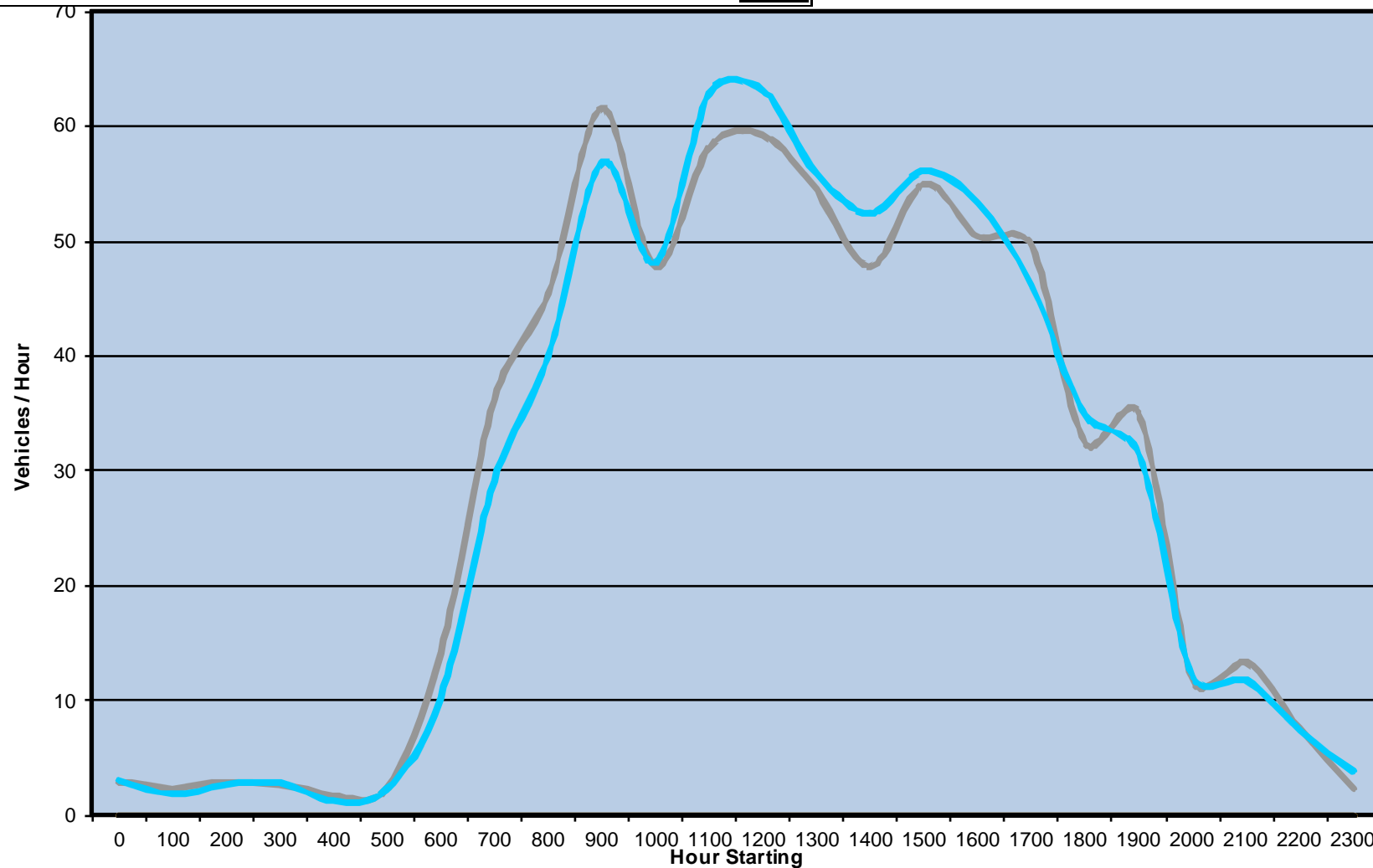

— Mon — Tue — Wed — Thu — Fri — Sat — Sun — 5 Day Ave — 7 Day Ave

- Mon
- Tue
- Wed
- Thu
- Fri
- Sat
- Sun
- 5 Day
- 7 Day